

KS2 SATs

Parent Information

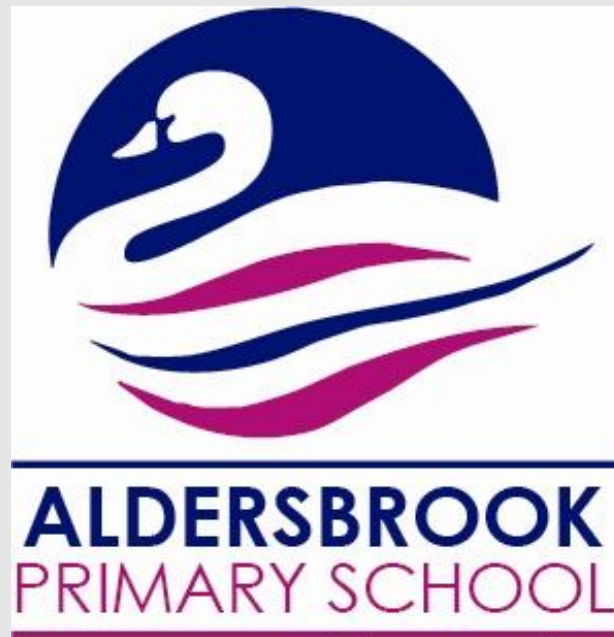

The Tests

Key Stage 2 SATs take place nationally 11 - 14th May 2026

Statutory tests will be administered in the following subjects:

- Reading (60 minutes)
- Spelling (approximately 15 minutes)
- Punctuation, Vocabulary and Grammar (45 minutes)
- Mathematics
 - Paper 1: Arithmetic (30 minutes)
 - Paper 2: Reasoning (40 minutes)
 - Paper 3: Reasoning (40 minutes)
- All tests are externally marked.
- As in recent years, writing and science will be teacher assessed internally.



Assessment and Reporting

Since 2016 SATs results have been given as a Scaled Score.

You will be given your child's raw score (the actual number of marks they get), alongside their scaled score and whether they have reached the expected standard set by the Department for Education

The range of scaled scores available for each KS2 test is:

- 80 - 99 working below the national Expected Standard
- 100 - 110 working at the Expected Standard
- 111 - 120 exceeded the Expected Standard

2025 Scaled Scores to attain
National Standard:

Reading	28/50
GPS	35/70
Maths	58/110

2025 Scaled Scores to attain
Greater Depth of Study:

Reading	40/50
GPS	54/70
Maths	95/110



Timetable for the week

Monday 11th May	Tuesday 12th May	Wednesday 13th May	Thursday 14th May	Friday 15th May
English Grammar, Punctuation, and Spelling (Papers 1 and 2)	English Reading	Mathematics (Papers 1 Arithmetic and 2 Reasoning)	SATS Breakfast Mathematics (Paper 3 Reasoning)	

We do two sittings each day. One for those children who do not get any extra time, and one for those who do.



Grammar, Punctuation & Spelling

- A spelling test is administered containing 20 words, which lasts approximately 15 minutes.
- A separate test is given on grammar, punctuation and vocabulary.
- This test lasts for 45 minutes and requires short answer questions including some multiple choice.
- Marks for these two tests are added together to give a total for grammar, punctuation and spelling.



Sample Questions

Grammar, Punctuation and Spelling Paper 1

8

Tick one box in each row to show whether the underlined word is a **possessive pronoun** or a **relative pronoun**.

Sentence	Possessive pronoun	Relative pronoun
That red cycle helmet is <u>mine</u> .		
I wear it when I ride the new bike <u>which</u> my uncle gave me.		
My bike goes much faster than <u>yours</u> .		

1 mark



Sample Questions

Grammar, Punctuation and Spelling Paper 1

18

Insert a **full stop**, a **question mark** and an **exclamation mark** in the correct places in the sentence below.

“ Did you see that goal I thought it was incredible ”

exclaimed Elle

1 mark



Sample Questions

Grammar, Punctuation and Spelling Paper 2 – 2025 spellings

Spelling

1. There was a brave _____ in the story.
2. The children walked home _____ the park.

Qu.	Spelling	Mark	Content domain reference
1	knight	1	S60 – words with 'silent' letters (i.e. letters whose presence cannot be predicted from the pronunciation of the word)
2	through	1	S59 – words containing the letter string <i>ough</i> S61 – homophones and near homophones (Years 3 and 4) homophones and other words that are often confused (Years 5 and 6)
3	rewarded	1	S38 – adding suffixes beginning with vowel letters to words of more than one syllable
4	adventure	1	S44 – words with endings sounding like /ʒə/ or /tʃə/
5	developed	1	S38 – adding suffixes beginning with vowel letters to words of more than one syllable



Reading

- The reading test consists of a single test paper with three reading texts. Children are given 60 minutes in total, which includes reading the texts and answering the questions.
- A total of 50 marks are available.
- Questions are designed to assess the comprehension and understanding of a child's reading.
- During the reading paper, a child's inference and deduction skills as well as their vocabulary and understanding of words are tested.
- Some questions are multiple choice or selected response. Others require short answers and some require an extended response or explanation.



Sample Questions

Reading Paper

15

(a) What evidence is there of Martine being stubborn in the way she behaved with her grandmother?

Give **two** points.

1. _____

2. _____

2 marks



Sample Questions

Reading Paper

27

Look at the paragraph beginning: *One of the victims...*

What does the word *invaders* suggest about the humans arriving on Mauritius?

1 mark



Sample Questions

Reading Paper

2

An intriguing game

Which word is closest in meaning to *intriguing*?

Tick **one**.

exciting

popular

challenging

interesting

1 mark



Mathematics

- Children will sit three tests: paper 1, paper 2 and paper 3.
- Paper 1 is arithmetic only and lasts 30 minutes, covering calculation methods for all operations, including use of fractions, percentages and decimals.
- Questions gradually increase in difficulty.
- Papers 2 and 3 cover problem solving and reasoning, each lasting for 40 minutes.
- Pupils will still require calculation skills but will need to answer questions in context and decide what is required to find a solution.



Sample Questions

Maths Paper 1: Arithmetic

14	$3.005 + 6.12 =$	<input type="checkbox"/>
		

32	$43 \overline{) 1118}$	<input type="checkbox"/>
	<p>Show your method</p> 	



Sample Questions

Maths Paper 2 / Paper 3 : Reasoning

22

Six identical right-angled triangles are arranged to make a rectangle.

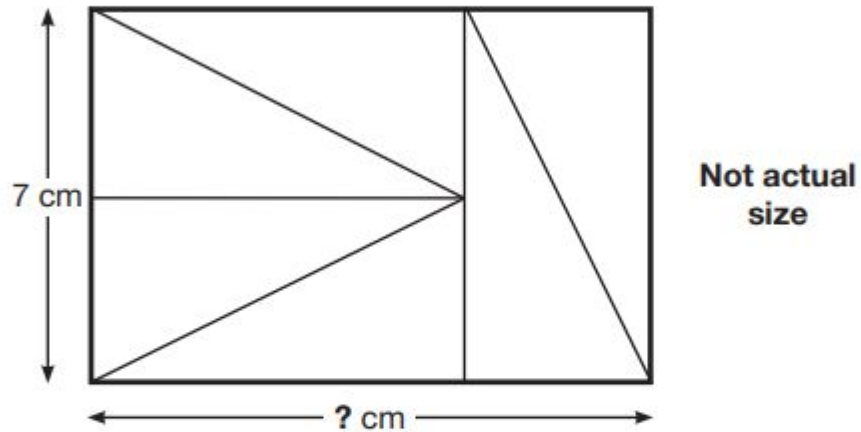

Calculate the **length** of the rectangle.

cm

1 mark



Sample Questions

Maths Paper 2 / Paper 3 : Reasoning

21

$$5,542 \div 17 = 326$$

Explain how you can use this fact to find the answer to 18×326

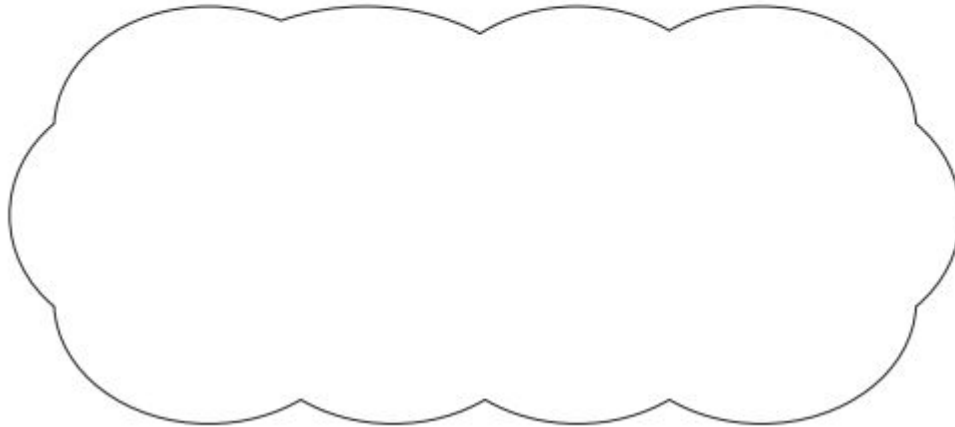

1 mark



What we do to support your child's wellbeing.

- At Aldersbrook we are committed to children experiencing a broad, balanced and engaging curriculum. We do not increase lesson time for Reading, Writing and Maths and continue to teach all subjects and attend education visits as normal, up until Summer Term 1.
- We have regular check ins with children around the time we are completing practise tests to gauge the feeling amongst the year group, in classes and individually. If we identify that additional support or adaptation to our approach is needed then we act on it.



What we do to support your child's wellbeing.

- We regularly remind children about the different avenues they can use to seek out help if they are struggling (e.g. speak to a trusted adult or use the chatterbox).
- We have an ELSA (Emotional Literacy Support Assistant) to support children and do regular check ins with individuals.
- **This year we plan to organise a wellbeing day on the Friday before the exam week where we can go to the local forest and children will participate in team bonding, art and mindfulness activities.**
- The Year 6 teachers and SLT are always available to discuss any concerns you may have throughout the year.



How to Help Your Child

- First and foremost, support and reassure your child that there is nothing to worry about and they should always just try their best. Praise and encourage!
- Focus on **progress** rather than scores.
- Ensure your child has the best possible attendance at school.
- Avoid busy weekends and evenings (especially the weekend *before* the SATS tests and late evenings that week).
- Reading, spelling and arithmetic (e.g. times tables) are always good to practise.
- Make sure your child has a good sleep and healthy breakfast every morning! **Don't forget our SATs celebration breakfast on the last morning of tests.**



Social Media

- Age restrictions apply to ALL social media sites, apps and games. Some, like Whatsapp, require children to be 13 years olds to use them.
- The school has a responsibility to inform children about E-Safety and this is taught throughout our Computing curriculum.
- Parents must take responsibility when children are using these apps or accessing these sites to monitor the usage.
- Any form of bullying or intolerant behaviour will be dealt with in accordance to our behaviour policy.
- How can you help your child?

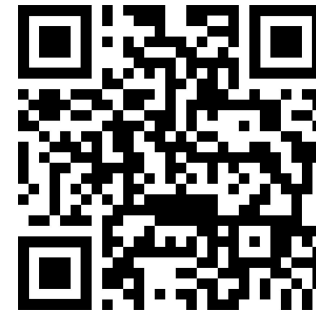

Secondary Application Process

Applications for secondary places are now open. **All admissions are organised online through the borough you live in** accessed through the links below:

Redbridge

<https://www.redbridge.gov.uk/schools/secondary-school-admissions/>

If you live in Redbridge you must apply through Redbridge even if you are interested in secondary schools in another borough.

Newham

<https://www.newham.gov.uk/schools-education/admissions-secondary-school/1>

If you live in Newham you must apply through Newham even though your child attends a primary school outside of Newham or you are only interested in secondary schools in another borough.

Waltham Forest

<https://www.walthamforest.gov.uk/content/applying-secondary-school-place>

If you live in Waltham Forest you must apply through Waltham Forest even though your child attends a primary school outside of Waltham Forest or you are only interested in secondary schools in another borough.

All applications close on 31st October 2025.

In recent years, some families who live outside of Redbridge and have applied for schools in the borough (e.g. Wanstead High School) have been rejected. Living outside of the catchment area, puts you at the lowest priority level for admissions. It is with this in mind, that if you are considering applying for Wanstead High, or any other Redbridge school, as your first choice and live outside of Redbridge, **that a preferable second choice of a school in your borough is selected on your application.**

Please do not assume sibling priority as this may have changed. Your council website will have more details. Further information regarding applications, catchment areas and admissions arrangements including how applications are considered, can be found on your council admissions website.

Visits and open evenings are arranged directly through the secondary school. If you have any questions regarding applications please contact your child's class teacher or Senior Leadership well before the application deadline.



Thank you for attending.

This presentation, including the links and QR code, will be uploaded to the Year 6 page on the school website.

If you have any further questions please ask, email or talk to us on the gate.

